

Tuning Instructions For Hipshot Extender Keys

For precise tuning use the following procedure:

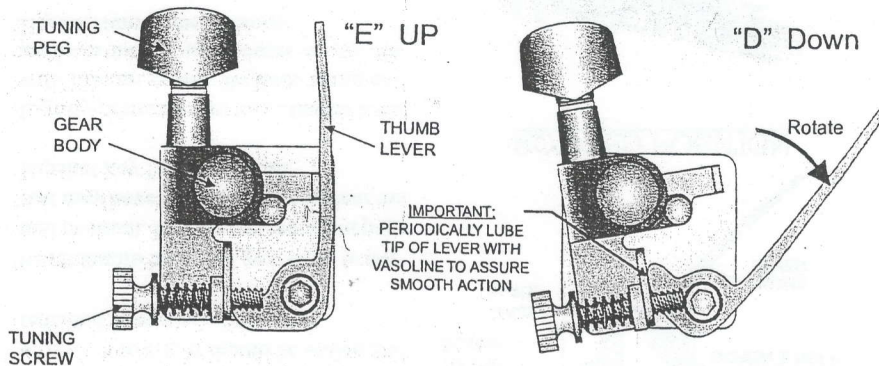

First tune the "E" note:

With the thumb lever in the up ("E") position the string up to "E". Always tune from flat up to pitch.

Now flip the thumb lever down and back up to settle the string. Check the tuning. If the string pitch down to about "E-Flat" and then bring it back up but this time leave it slightly flat. Flip the thumb lever down and up one time and recheck tuning.

If the pitch is still flat, give the tuning peg a very small turn, flip lever down and back up, and recheck your tuning again. If you overshoot, back down and repeat procedure.

Remember that tuning problems may also be caused by a bad quality or poorly notched nut. It is advised to install a high quality graphite nut or to use some graphite grease on the notch of the nut in order to decrease friction. Remember to properly wind the strings and use quality strings

HIPSHOT
PRODUCTS, INC.

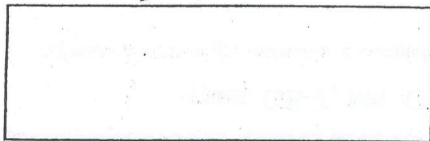

Now tune the "D" note:

Flip the thumb lever down to the "D" position. Check your tuning. If your string is out of tune, flip the thumb lever back to the "E" position and adjust the small "D" tuning screw, Do not turn the peg!

If the pitch is too high – turn the tuning screw counter-clockwise, increasing the distance between its head and the head of the lever axis screw.

If the pitch is too low – turn the tuning screw clockwise, decreasing the distance between its head and the head of the lever axis screw.

Flip the lever down to the "D" position and recheck your tuning. Repeat this procedure until "D" is in tune. Note: on many guitars, the string may actually be tuned down as far as low "C". The above sounds harder than it really is. With a little practice it will become nature and will only take a few seconds.

Every time you turn the tuning peg, you must give the thumb lever one quick flip down and up to set the string and give you the true tuning of the string.

Your new Hipshot will provide you with high accuracy in tuning and retuning. The finest hardware and materials have been selected to insure high reliability for many years.

Installation Instructions For Extender Keys

Types: GB-7, M4, GT-1, GT-2 or similar

(Please read through instructions completely before beginning your installation.)

1. Remove the existing low string peg.
2. Remove the Hipshot key's drawnut and washer, and place Hipshot key in position on instrument neck. Apply washer and drawnut, but leave loose.
3. Loosen the tuning screw. Rotate the thumb lever and gear body to expose the alignment screw hole in the key baseplate (on some instruments it may be necessary to temporarily remove an adjacent peg to accomplish this).
4. Normally the alignment screw hole in the baseplate will match the existing screw hole in the instrument neck when the baseplate and key are aligned.
5. With the baseplate aligned, install provided flat head alignment screw. Tighten screw and drawnut to firmly mount baseplate to instrument. If the original hole do not match this on the baseplate or if it is too big, it should be sealed and redrilled to ensure a tight hold.
6. Reset thumb lever and gear body to normal position. Replace any adjacent pegs that may have been removed to clear the Hipshot key for installation.
7. Lightly lubricate cam tip of thumb lever with lithium grease. Replace string and perform tuning procedures as per the Hipshot tuning instructions.

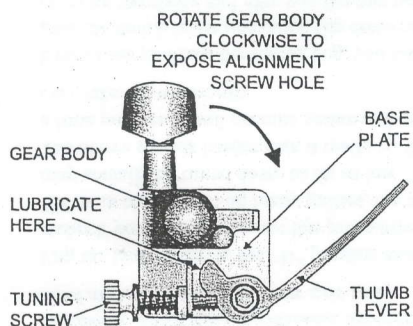

NORMAL POSITION

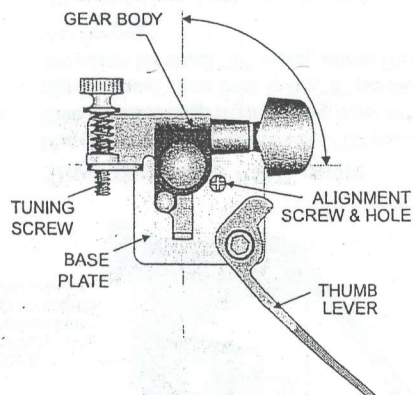

ROTATED POSITION

HIPSHOT
PRODUCTS, INC.